



# DESIGN NOTES

## Low Input Voltage CCFL Power Supply – Design Note 133

Fran Hoffart

Cold cathode fluorescent lamps (CCFLs) are often used to illuminate liquid crystal displays (LCDs). These displays appear in laptop computers, gas pumps, automobiles, test equipment, medical equipment and the like. The lamps themselves are small, relatively efficient and inexpensive, but they must be driven by specialized power supplies. High AC voltage (significantly higher than the operating voltage) is needed to start the lamp. A sinusoidal waveform is desired, the current must be regulated, efficiency should be high and the power supply must be self-protecting in the event of an open-lamp condition.

CCFL power supplies consisting of a Royer class, self-oscillating sine wave converter driven by an LT<sup>®</sup>1513 switching regulator are shown in Figures 1 and 2. These circuits are especially suited for low voltage operation, with guaranteed operation for input voltages as low as 2.7V and as high as 20V. High voltage output regulated Royer converters, although capable of 90% efficiency, are not well-suited for low input voltage operation and have diffi-

culty operating with input voltages below 5V. The circuits shown here overcome this limitation while providing efficiency exceeding 70%.

The LT1513 is a 500kHz current mode switching regulator featuring an internal 3A switch and unique feedback circuitry. In addition to the Voltage Feedback pin ( $V_{FB}$ ), a second feedback node ( $I_{FB}$ ) provides a simple means of controlling output current in a flyback or SEPIC (single-ended primary inductance converter) topology.

Two CCFL driver circuits are shown. The first (Figure 1) drives one end of the lamp, with the other end effectively grounded. Lamp current is directly sensed at the low side of the lamp, half-wave rectified by D4, and then used to develop a feedback voltage across R2. This voltage, filtered by R3 and C6, drives the  $V_{FB}$  pin (2) to complete the feedback loop. The RMS lamp current is tightly regulated and is equal to  $2.82V/R2$ .

LT, LTC and LT are registered trademarks of Linear Technology Corporation.

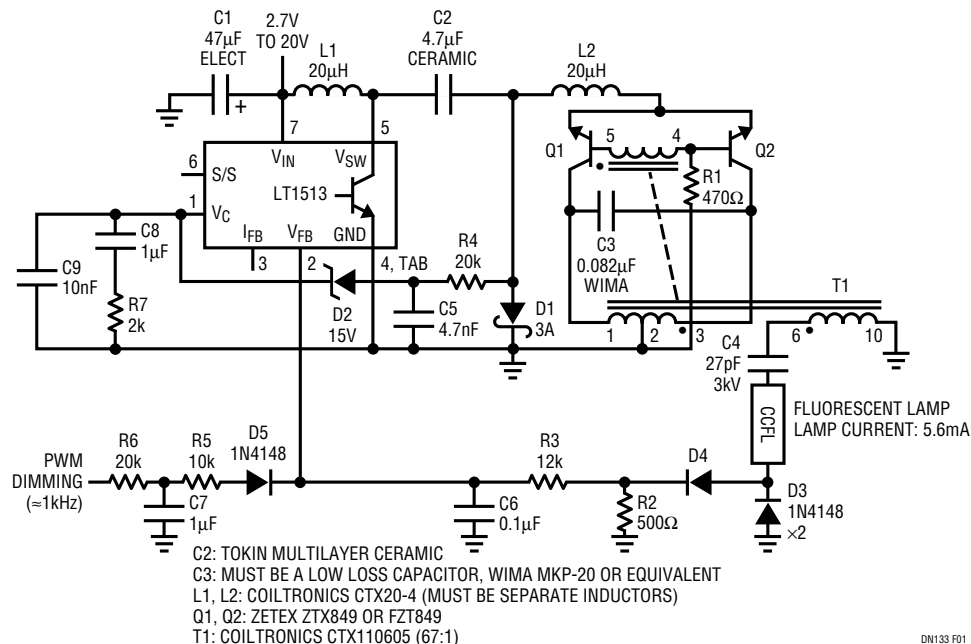

DN133 F01

Figure 1. CCFL Power Supply for Grounded Lamp Configuration Operates on 2.7V

Because of the high voltage 60kHz lamp drive used by the CCFL lamps, any stray capacitance from the lamp and lamp leads to ground will result in unwanted parasitic current flow, thus lowering efficiency. The lamp and display housing often have relatively high stray capacitance, which can dramatically lower the overall circuit efficiency.

In some displays that exhibit high capacitance, a floating lamp drive can provide much higher overall efficiency. The operation of the floating lamp circuit shown in Figure 2 is similar to that of the grounded lamp, except for the transformer secondary and the feedback method used. In this circuit, the lamp current is controlled by sensing and regulating the Royer input current. This current is sensed by R2, filtered by R3 and C6 and fed into the I<sub>FB</sub> pin (3) of the LT1513, thus completing the feedback loop. The sense voltage required at the I<sub>FB</sub> pin is -100mV. Because the Royer input current rather than the actual lamp current is regulated, the regulation of Figure 2 is not as tight as that of Figure 1.

There are three considerations to keep in mind when laying out a PC board for these supplies. The first is related to high frequency switcher characteristics. The 500kHz switching frequency allows very small surface mount components to be used, but it also requires that PC board traces be kept short (especially the input capacitor, Schottky diode and LT1513 ground connections). The second item is the high

voltage section, which includes T1's secondary, the ballasting capacitor C3 and the lamp wiring. Lamp starting voltages can easily exceed 1000V, which can cause a poorly designed board to arc, resulting in catastrophic failure. Board leakages can also increase dramatically with time, resulting in destructive field failures. Third, surface mount components rely on the PC board copper to conduct the heat away from the components and dissipate it to the surrounding air. Good thermal PC board layout practices are necessary.

In both circuits, lamp current can be adjusted downward to provide lamp dimming. A 5V pulse width modulated (PWM) 1kHz signal or an adjustable DC voltage can provide a full range of dimming. In Figure 1, 100% duty cycle represents minimum lamp brightness, whereas in Figure 2, 100% duty cycle is maximum lamp brightness.

The lamp drive is a constant current, and without protection circuitry, voltages could become very high in the event of an open-lamp connection, causing transformer arcing or LT1513 failures. Open-lamp or high input voltage fault protection is provided by R4, C5 and the 15V Zener D2, which limit the maximum voltage available for the Royer converter.

See Application Notes 49 and 65, Design Note 99 and the LT1513 Data Sheet for additional information on driving CCFL lamps.

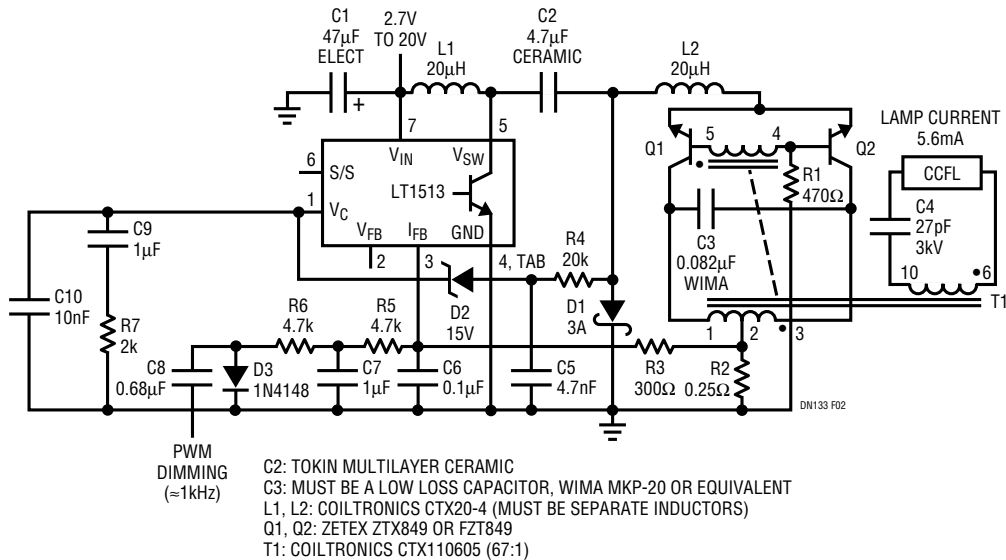

Figure 2. CCFL Power Supply for Floating Lamp Configuration Operates on 2.7V

For literature on our Switching Regulators, call **1-800-4-LINEAR**. For applications help, call (408) 432-1900, Ext. 2361